

505 machine information

The Pronova 505 bagging machine is the latest addition to our range of standard machines. With a simpler design and fewer components than the rest of the machines in the 500 series it is particularly well suited for smaller, growing productions that have packed all manually and now need to develop the packaging process to become a little more automated and much more efficient.

The 505 opens up and seals the bags automatically and with the patented Sesam opening rails you have many bags open at a time for filling. By simply loosening two knobs you can instantly and very easily change the bag opening and adjust it to fit the product's size and shape - from a very narrow and thin up to a square opening.



Highly versatile design

-easily adjusted to product.

Various bag sizes

-from 50 up to 200 mm wide bags.

Various bag applications

-reclosability, perforation, headers, pin-packs etc.

Intermittent bag feed

Various filling options

For manual filling, we have the 505 with work table with boxes for unloading. With its flexible design, the Pronova 510 bagging machine is also well prepared to suit existing filling lines, such as weighers, counters and manufacturing machines.

Good ergonomics

The design of the work place is critical for how fast products can be packed. Good ergonomics is also the way to avoid work related injuries, and we have the knowledge and the experience it takes to design operator-friendly and efficient work stations.

PLC system

The machine is equipped with a Mitsubishi Melsec PLC system. The operator panel gives all necessary machine information and its touch button display with universal symbols is highly operator-friendly.

Standard features

- Preset counter for automatic stop after preset number of bags:
- Automatic intermittent bag feeding with adjustable stop time:

Optional equipment

- Thermal transfer printer
- Label equipment
- Ink jet printer



PRONOVA

PACKAGING SYSTEMS

The Pronova 505 bagging machine comes in two different versions.

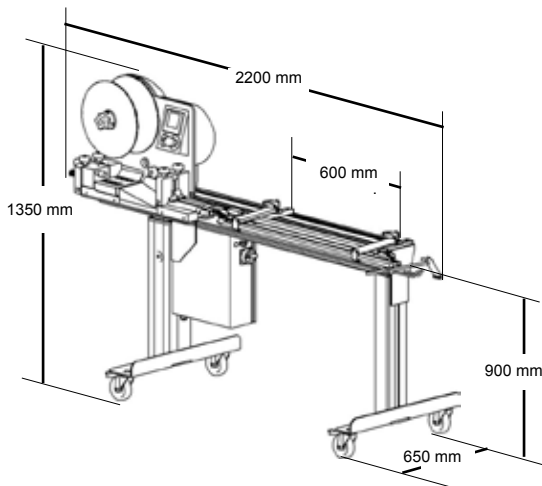

Basic with Sesam or Classic opening rails.

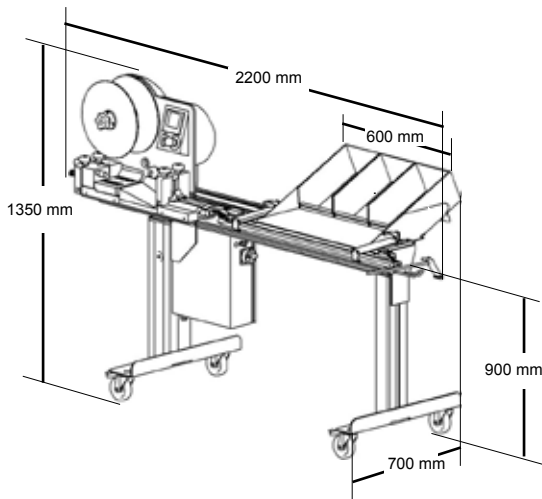

With work table for efficient and comfortable filling of smaller parts.

- An ergonomic work station for manual packaging.

Both designs can be added with labellers or imprints straight onto the bags. This is done on empty bags prior to the point of filling.

Bags can hang free without support up to a weight of 300-400 grams per 100 mm bag width.

For heavier products, we recommend our larger machine model, the 510 or the 525 with the optional supporting conveyor belt. There are also limitations for the total weight that can hang from the opening rails.

Technical specifications Pronova 505

Weight:	Approx. 105 kg
Standard sealing speed:	4 m/min.
Power:	1,3 kW
Electrical supply:	230 V 1-phase

QUALITY

The patented Pronova Packaging Systems stands for quality and responsibility.

Every step of the way is guided by the ISO 9001 standards –from the designing and production of our machines and packaging material through to delivery, service and education.

Our machines are of course CE-marked.

The packaging machines are all through designed with few moving parts and with a simplicity that makes them easy to operate and maintain. The sealing unit is easily dismantled without the use of any tools.

Our licensees and distributors are all equally taking full responsibility for delivered machines and material, and they all possess good skills in installation, education and service.



For further information, please contact us at:

*Pronova AB
Olofsdalsvägen 26
302 41 Halmstad
Sweden*

*Tel.: +46 (0)35 17 19 00
Fax: +46 (0)35 17 19 19*

*sales@pronovaab.se
www.pronovasweden.eu*